

CONSTRUCTION/ASSEMBLY NOTES:

- PANEL SURFACES:** SOLID FACE IS 16 GA. COLD ROLLED STEEL WITH A-60 GALVANEAL COATING. PERFORATED FACE IS 22 GA. WITH $\frac{3}{32}$ " HOLES ON $\frac{3}{16}$ " STAGGERED CENTERS.
- PANEL FILL:** NON-COMBUSTIBLE, SOUND ABSORBING FIBERGLASS
- FINISH:** STD. FINISH IS "PAINT READY" GALVANEAL. THERMOSETTING TGIC POLYESTER POWDER COATING IS AVAILABLE. COLOR TO BE SELECTED BY ARCHITECT/CUSTOMER FROM STANDARD COLOR CHART SUPPLIED BY NOISE BARRIERS, LLC. COLOR TO BE: _____
- PANELS ARE INSTALLED VERTICALLY AND SUPPORTED BY THE CONTINUOUS STRUCT. STEEL BOTTOM ANGLE AND ANCHORED WITH SELF-TAPPING SCREWS TO CONTINUOUS STRUCT. STEEL TOP ANGLE.

BARRIER PANEL ACOUSTIC PERFORMANCE

SOUND TRANSMISSION LOSS, dB

| OCTAVE BAND CENTER FREQUENCIES (Hz) | 125 | 250 | 500 | 1K | 2K | 4K | STC |
|-------------------------------------|-----|-----|-----|----|----|----|-----|
| QUIETLINE H/P-42 V-STACK PANEL | 23 | 31 | 40 | 49 | 56 | 62 | 42 |

*All data in accordance with ASTM E90-99 and E413-87

SOUND ABSORPTION COEFFICIENTS

| OCTAVE BAND CENTER FREQUENCIES (Hz) | 125 | 250 | 500 | 1K | 2K | 4K | NRC |
|-------------------------------------|------|------|------|------|------|------|-------------|
| QUIETLINE H/P-42 V-STACK PANEL | 0.68 | 1.06 | 1.12 | 1.08 | 1.03 | 0.98 | 0.95 (1.05) |

*All data in accordance with ASTM C423-80a and E795-00

BARRIER WALL
ISOMETRIC VIEW

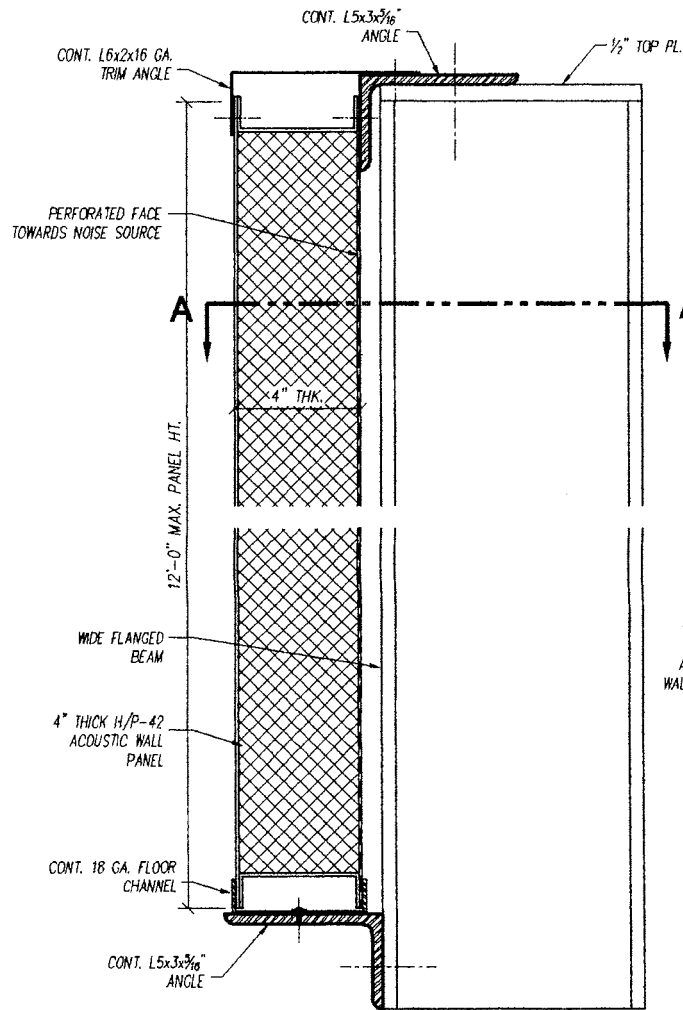
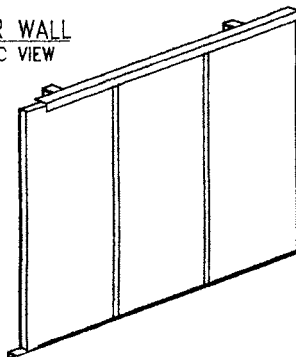

WALL SECTION DETAIL

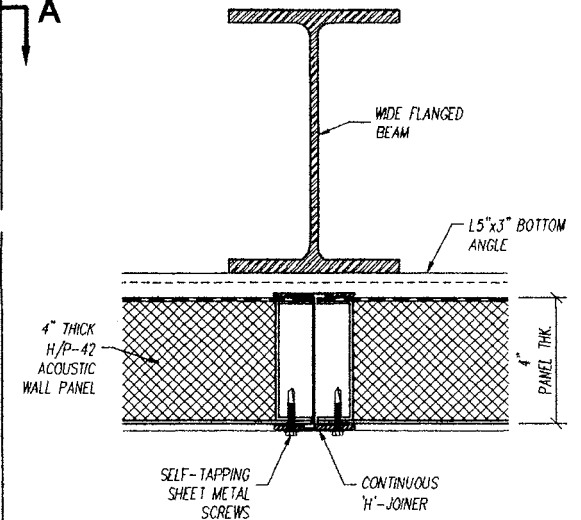

SECTION A-A

| REVISIONS | DESCRIPTION | DATE | BY | DESCRIPTION | QUIETLINE H/P-42 BARRIER PANEL | |
|-----------|-------------|------|----|-------------|--------------------------------|-------------|
| | | | | | PROJECT | |
| | | | | DRAWN BY | SCALE | DRAWING NO. |
| | | | | DATE | SHEET | H/P-42-1 |



Noise Barriers, LLC

1207 Remington Rd., Suite E
Schaumburg, IL 60173
Phone: (847) 843-0500
Fax: (847) 843-0501

www.noisebarriers.com

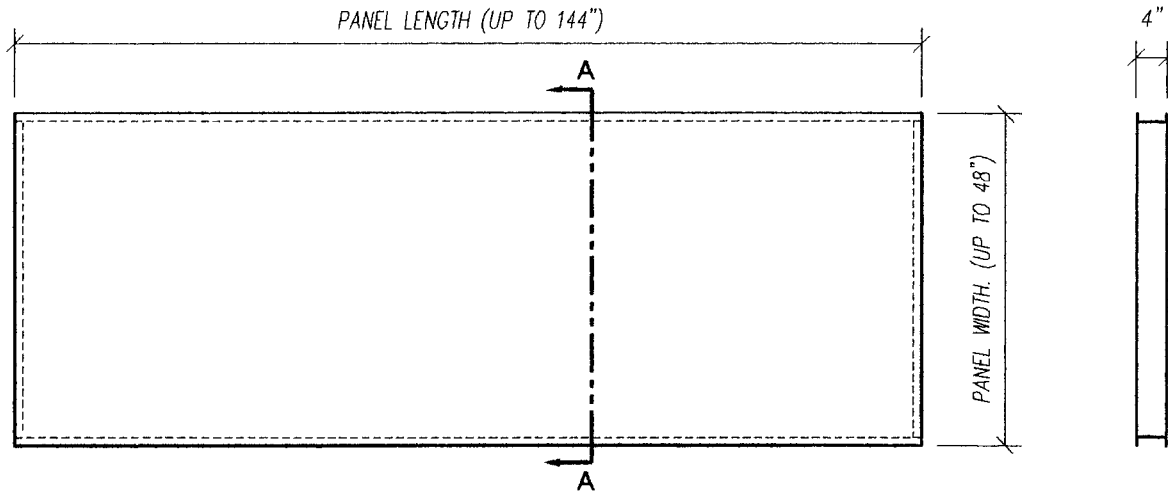

H/P-42 ACOUSTIC BARRIER WALL PANEL
FRONT & SIDE ELEVATIONS

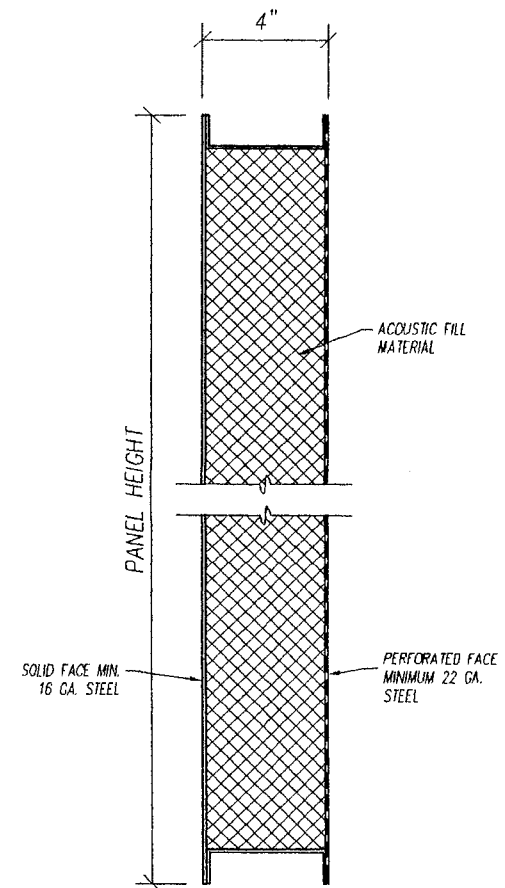

SECTION A-A

| PANEL No. | QTY. | PANEL LENGTH | PANEL HEIGHT |
|-----------|------|--------------|--------------|
| | | | |
| | | | |
| | | | |
| | | | |
| | | | |
| | | | |
| | | | |
| | | | |
| | | | |
| | | | |

'H/P-42' BARRIER PANEL

| DESCRIPTION | DATE | BY | DESCRIPTION |
|-------------|------|----|--------------------------------|
| | | | QUIETLINE H/P-42 BARRIER PANEL |
| | | | PROJECT |
| | | | DRAWN BY |
| | | | SCALE |
| | | | PROJECT NO. |
| | | | DATE |
| | | | SHEET |
| | | | H/P-42-2 |

Noise Barriers, LLC
 1207 Remington Rd., Suite E
 Schaumburg, IL 60173
 Phone: (847) 843-0500
 Fax: (847) 843-0501
www.noisebarriers.com