

CONSTRUCTION/ASSEMBLY NOTES:

- PANEL SURFACES:** SOLID FACE IS 14 GA. COLD ROLLED STEEL WITH A-60 GALVANNEAL COATING. PERFORATED FACE IS 22 GA. (16 GA. IF OVER 10'-0" IN LENGTH) WITH $\frac{3}{32}$ " HOLES ON $\frac{3}{16}$ " STAGGERED CENTERS.
- PANEL FILL:** HIGH DENSITY, SEMI-RIGID, NON-HYGROSCOPIC FIBERGLASS. THE MAXIMUM UNSUPPORTED HEIGHT OF FILL SHALL NOT EXCEED 23 $\frac{1}{2}$ ".
- FINISH:** THERMOSETTING TGIC POLYESTER POWDER COATING IN COLOR SELECTED BY ARCHITECT/CUSTOMER FROM STANDARD COLOR CHART SUPPLIED BY NOISE BARRIERS, LLC. **COLOR TO BE:** _____
- PANELS SHALL BE LOWERED CONSECUTIVELY BETWEEN VERTICAL WIDE FLANGED BEAMS. BARRIER WALL SHALL BE DESIGNED TO WITHSTAND WINDLOAD IN ACCORDANCE WITH THE SPECIFIED LOCAL CODE REQUIREMENTS OF THE PROJECT. REFER TO INSTALLATION DETAILS 'OPTION 1' & 'OPTION 2' FOR ALTERNATES.
- THE BARRIER PANEL ARE DESIGNED TO WITHSTAND WIND LOADS OF 40 POUNDS PER SQUARE FOOT, BOTH NEGATIVE AND POSITIVE.
- STRUCTURAL STEEL COLUMNS ARE PRIME PAINTED & FINISH PAINTED IN COLOR TO MATCH PANELS. PAINT TO BE SHOP APPLIED AND AIR DRIED.

BARRIER PANEL ACOUSTIC PERFORMANCE

SOUND TRANSMISSION LOSS, dB

OCTAVE BAND CENTER FREQUENCIES (Hz)	125	250	500	1K	2K	4K	STC
QUIETLINE SL-R BARRIER PANEL	34	40	35	45	49	52	37

*All data in accordance with ASTM E90-99 and E413-87

SOUND ABSORPTION COEFFICIENTS

OCTAVE BAND CENTER FREQUENCIES (Hz)	125	250	500	1K	2K	4K	NRC
QUIETLINE SL-R BARRIER PANEL	0.92	1.15	1.22	1.13	1.08	1.04	0.95 (1.15)

*All data in accordance with ASTM C423-90a and E795-00

BARRIER WALL
ISOMETRIC VIEW

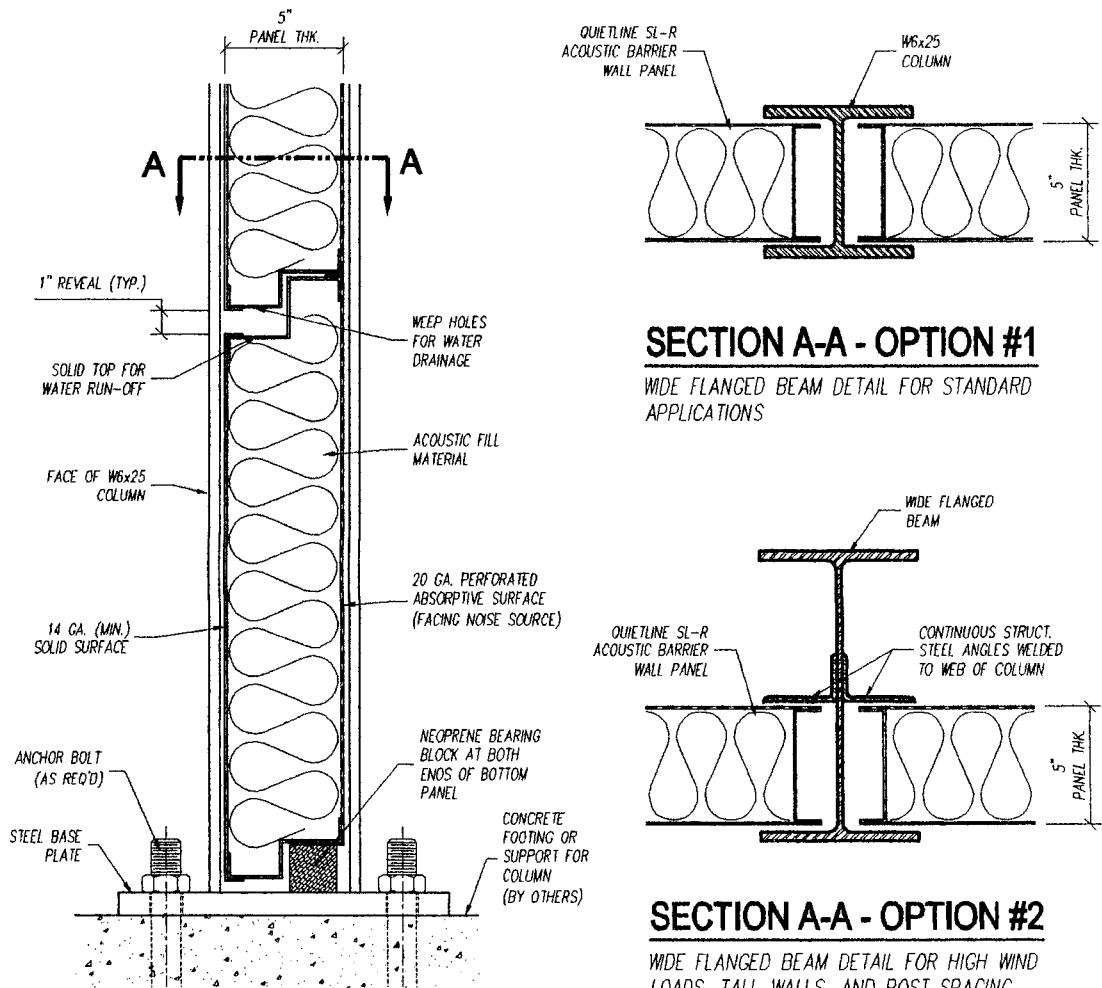
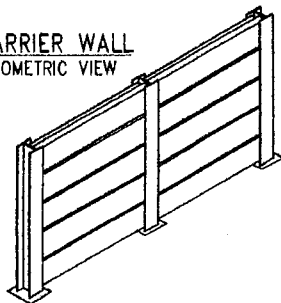

WALL SECTION DETAIL

REVISIONS	DESCRIPTION	DATE	BY	DESCRIPTION
				QUIETLINE 'SL-R' BARRIER PANEL
				PROJECT
				DRAWN BY
				SCALE
				DRAWING NO.
				SLR-1
				DATE
				SHEET

 **Noise Barriers, LLC**
 1207 Remington Rd., Suite E
 Schaumburg, IL 60173
 Phone: (847) 843-0500
 Fax: (847) 843-0501
www.noisebarriers.com

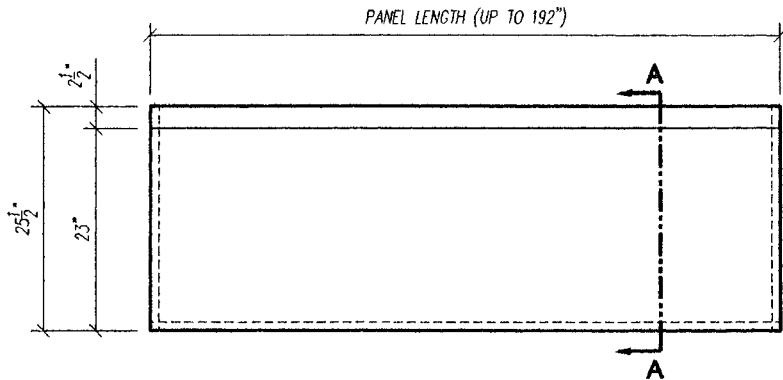

'SL-R' ACOUSTIC BARRIER WALL PANEL
FRONT & SIDE ELEVATIONS

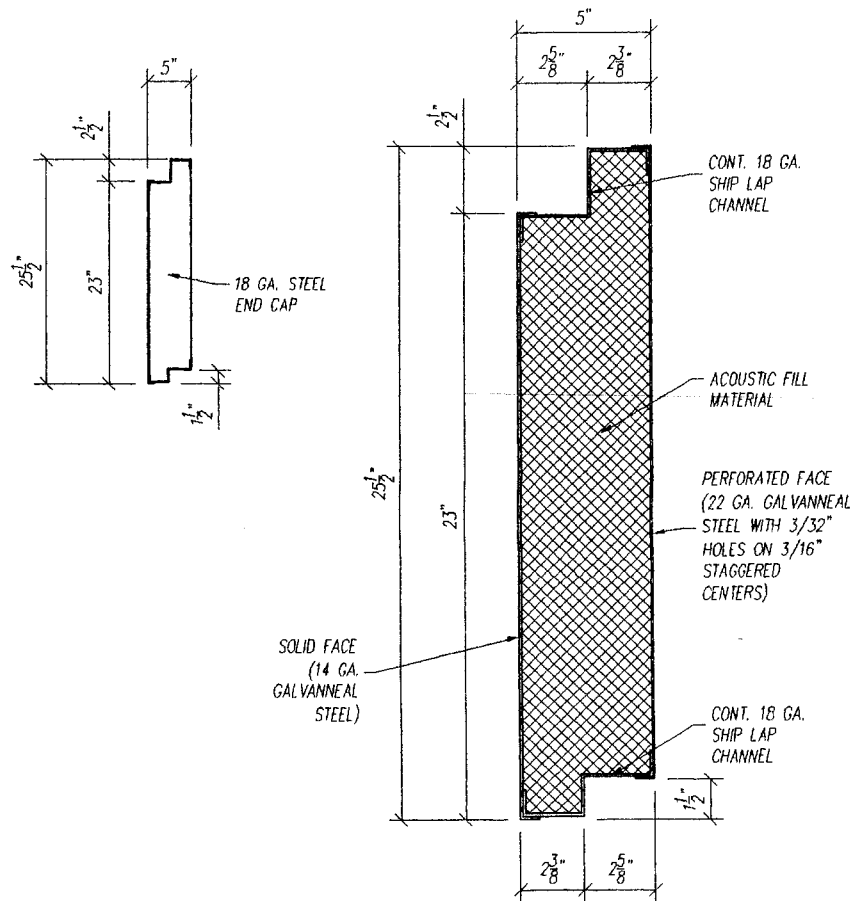

SECTION A-A

PANEL No.	QTY.	PANEL LENGTH

'SL-R' BARRIER PANEL

DESCRIPTION	DATE	BY	DESCRIPTION
			QUIETLINE 'SL-R' BARRIER PANEL
			PROJECT
			DRAWN BY
			SCALE
			DRAWING NO.
			SLR-2
			DATE
			SHEET

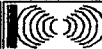
Noise Barriers, LLC
 1207 Remington Rd., Suite E
 Schaumburg, IL 60173
 Phone: (847) 843-0500
 Fax: (847) 843-0501
www.noisebarriers.com